

# Sx-IP

## IP67 versatile Xenon Flash

# USER GUIDE

Hardware revisions C04 and higher



## 1 TABLE OF CONTENTS

2	Safety instructions .....	3
2.1	Safety waring .....	3
2.2	Safety icons .....	3
3	Main characteristics .....	4
3.1	IP rating .....	4
3.2	Power supply requirements .....	4
3.3	Maximum power .....	4
4	product Identification .....	6
5	Quick start .....	7
5.1	Service cables and power supply .....	7
5.2	Service software .....	7
5.1	Modbus manual .....	7
5.2	Python library .....	7
6	Mecanical .....	8
6.1	Dimenssions .....	8
6.2	Holding the box: .....	8
7	Hardware interface .....	9
7.1	Basic connections .....	9
7.2	Power supply .....	9
7.3	Signals connector .....	10
7.4	Address / level hardware selector (option) .....	11
7.5	Using M12-5pts connectors for daisy chaining Sx-IP devices .....	11
7.6	Dsub15 interface (option) .....	12
7.7	RS485 interface .....	12
7.8	Discrete IOs .....	13
8	Configuration .....	17
8.1	Hardware settings .....	17
9	Maintenance instructions .....	18
9.1	Flash tube replacement .....	18
9.2	Fuses replacement: .....	19

## 2 SAFETY INSTRUCTIONS

### 2.1 SAFETY WARNING

#### 2.1.1 ELECTRICAL SHOCKS

Sx-IP device stores up to 400J of energy in high voltage capacitors charged at almost 300 V. **Sx-IP housing integrity must be preserved.** If the housing is damaged (cracked or broken glass, infiltration of water...) the device must be disconnected from supply and removed from the system.

**Opening the housing is reserved to qualified and trained staff and shall be done accordingly to maintenance instructions.**

#### 2.1.2 LIGHT

Due to the extreme high power of light emission, operators and people in sight of the flash must be protected against direct impact of the light output



**Any other utilization of the Sx-IP that is not described in the following document can lead to a dangerous situation**



**In case of unexpected behavior of the product, the power supply must be cut off by removing the connector**

### 2.2 SAFETY ICONS



#### **Disposal of Electrical and Electronic Equipment in Private Households In the European Union, Norway, Iceland and Liechtenstein:**

This symbol on the product indicates that this product shall not be treated as household waste. Instead, it should be taken to an applicable collection point for the recycling of electrical and electronic equipment. By ensuring this product is disposed of correctly, you will help prevent potential negative consequences to the environment and human health, which could otherwise be caused by inappropriate waste handling of this product.

#### **Continuous Current:**



This symbol on the product indicates that this product shall be powered with continuous current.



#### **Risk of Electrical Shock:**

This symbol on the product indicates that dangerous voltages are generated by the product and can be dangerous for human without precaution.



#### **Warning:**

This symbol on the product or the manual indicates that particular attention must be taken.



#### **Read the Manual**

This symbol on the product indicates that the manual shall be read before any operation.

## 3 MAIN CHARACTERISTICS

### 3.1 IP RATING

Sx-IP has an **IP67** rating.

Sx-IP is totally protected from dust.

Sx-IP is protected from powerful water jets.

Sx-IP support immersion at 1m for 30min

### 3.2 POWER SUPPLY REQUIREMENTS

Sx-IP can operate from **10Vdc to 30Vdc** <sup>(1)</sup>. Input current can be up to **6A**.

Sx-IP is protected against over-voltages and reverse voltages up to +/-36Vdc.

Care must be taken to keep cables' voltage drop small enough not to cause undervoltage detection.

Low input voltages reduce recharge performances.

Design notes:

<sup>(1)</sup> C04 hardware revisions have 10.2Vdc to 28.8Vdc input voltage range.

### 3.3 MAXIMUM POWER

#### 3.3.1 INSTANTANEOUS CHARGE POWER

Sx-IP instantaneous charge power is approximately:

- **55W at 12Vdc** input voltage (40W for C04 and C05 hardware revisions)
- **70W at 24Vdc** input voltage (50W for C04 and C05 hardware revisions)

#### 3.3.2 AVERAGE POWER

To protect the flash tube from over-heating, the output power is software limited to **50W** <sup>(1)</sup> with 10s averaging period.

Design notes:

<sup>(1)</sup> The software power limit may be different according to the flash configuration.

### 3.3.3 THERMAL LIMIT

Sx-IP has been designed to operate continuously at **30W average power in all conditions**.

Effective maximum average power is limited by the **internal temperature protection** that is triggered when the internal temperature reaches **80°C**.

In fact, maximum average power is limited by the ability of the case to dissipate power, so maximum average power is mainly affected by:

- Ambient temperature
- Air flow around the case
- Direct solar energy input

Sx-IP has **half an hour thermal inertia**.

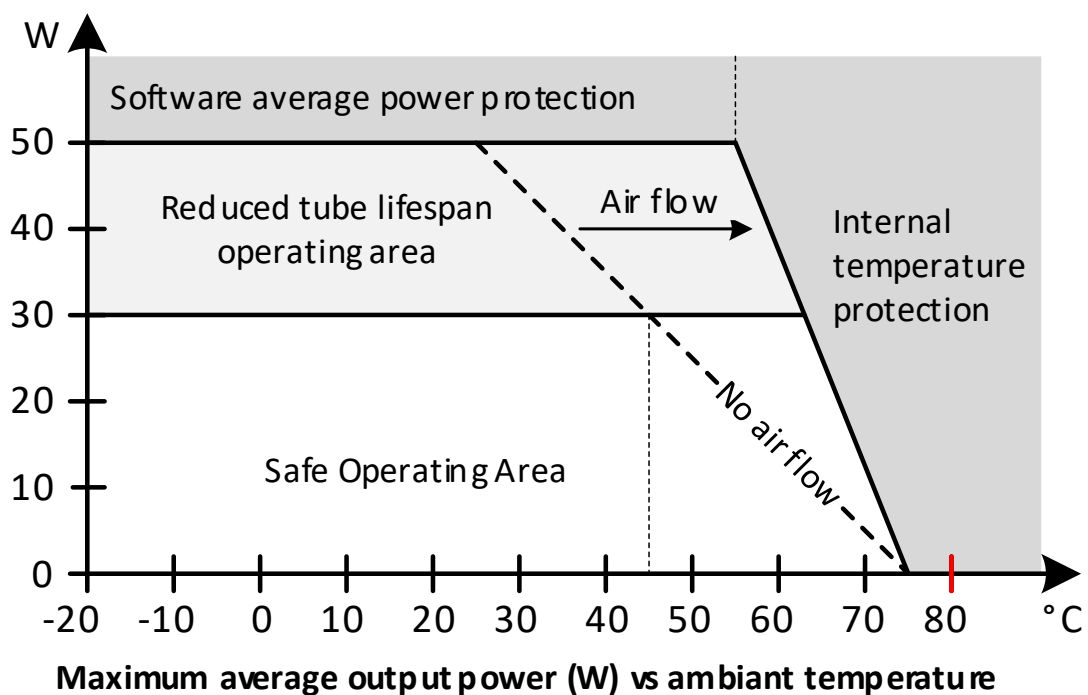

## 4 PRODUCT IDENTIFICATION

Sx-IP are identified thanks to a sticker on its rear side.

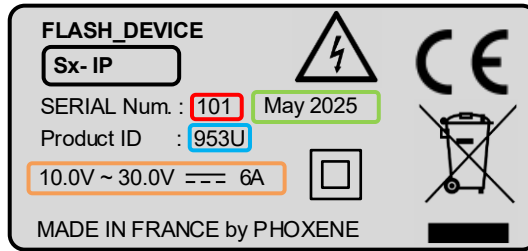

It includes following information:

- **Serial number**
- **Manufacturing date**
- **Product ID.:**
  - Product ID identify main characteristics of the product
  - Detailed characteristics are stored in a database with the serial number as reference
- **Power supply requirements**

## 5 QUICK START

Phoxene can provides means for a rapid set-up of Sx-IP devices.

### 5.1 SERVICE CABLES AND POWER SUPPLY

The service cable includes power supply terminals, Modbus link on USB and triggers inputs on a wire-ended cable. This cable allows very quick bring-up for R&D, evaluation or servicing. It has no guaranteed IP grade.



### 5.2 SERVICE SOFTWARE

A service software is available for window platforms and Linux platforms on request. It allows configuration, monitoring, test and firmware update of Sx-IP devices.

**Sx-IP Service software v2.0**

Modbus COM management: USB Serial Port (COM8) | Device Address: 1 | Scan | Auto-Refresh

Setting registers	Value	Unit	R	W
Serial Number	104			
Date code (Y,WW)	w29 2025	6429		
Hardware rev.	C.05	773		
Product id.	1302U	1302		
Modbus add. preset	1	1		
Energy level preset 1	11 11	2827		
Energy level preset 2	11 11	2827		
Energy level preset 3	11 11	2827		
Energy level preset 4	11 11	2827		
Glitch filter	10µs	10		
Flash delay	10µs	10		
Sync pulse delay	10µs	10		
Sync pulse width	10µs	10		
Triggers input select.	IN5 IN6 ----	101		
Misc. input select.	0	0		
Inputs config	0b0	0		
Outputs config	0b0	0		
Energy hard select.	0 0 0 0	0		
Address hard sel. 0	0 0 0 0	0		
Address hard sel. 1	0 0 0 0	0		
Missed flash weight	100	100		
Health threshold	1000	1000		
Reset on failure	5.0s	50		
R/W All registers				

Supervision registers	Value
Soft id	SxIP 2.02
Reset source	Software
Modbus address	1
Input voltage	13.98V
Min Input voltage	13.42V
HT voltage	270.0V
Temperature	28°C
Min and Max temp.	22°C 57°C
Flash power	0.15W
Fan speed	4590rpm
HW sel Add & Energy	1 0
Energy levels [1-4]	11 11 11 11
Ftimes [1-4]	218µs 218µs 218µs 218µs
Energy [1-4]	60.00J 60.00J 60.00J 60.00J
Target energy	60.00J
Flash energy	61.40J
Glitch count	0
Was not ready count	0
Flash error count	0
Health indicator	0
Start count	55
Time count	1241min
Total time count	2352min
Flash count	5
Total flash count	6637
Flash tube count	6637
Read all registers	READ

**Flag registers**

- Status flags:**
  - Initialized (Green)
  - Ready (Green)
  - Com error (Yellow)
  - Error (Red)
  - Failure (Red)
  - Alt. energy level (Green)
  - Fully charged (Green)
- Failure flags:**
  - Flash failure (Red)
  - Fan failure (Red)
  - DCDC error (Red)
  - Simmer error (Red)
- Error flags:**
  - Vin out of range (Yellow)
  - HT out of reg (Yellow)
  - Was not ready (Yellow)
  - Energy reg err (Yellow)
  - Flash error (Yellow)
  - Fan error (Yellow)
  - Overtemp (Yellow)
  - Internal error (Yellow)
  - Config error (Yellow)
  - Overload (Yellow)
- Com errors:**
  - RS485 Framing err (Yellow)
  - RS485 Parity error (Yellow)
  - RS485 Fifo overflow (Yellow)
  - RS485 Buf. overflow (Yellow)
  - Modbus Frame err (Yellow)
  - Modbus CRC error (Yellow)
- IO state:**
  - Input 1-6 (Green)
  - Sel bit 0-3 (Green)
  - Output 1-8 (Green)

**Commands**

- Functional: Reset, Set init done, Clear, Flash, Save settings, Clear tube count

**Logs**

2025-07-31 13:48:32,116 - INFO : Connected to COM8

Log options: Clear logs, INFO

### 5.1 MODBUS MANUAL

All information needed to go on with Sx-IP configuration and supervision through the Modbus communication link can be found in the Sx-IP Modbus Manual.

### 5.2 PYTHON LIBRARY

Phoxene provide a python driver that can be used to manage PHOXENE's flash devices.



## 6 MECHANICAL

### 6.1 DIMENSIONS

Sx-IP dimensions are 180 x 142 x 100mm (excluding screws and connector)

Weight is between 1600g and 2000g according to the configuration.

### 6.2 HOLDING THE BOX:

It is possible to attach Sx-IP devices on any face by using stainless M3 stainless screws directly between the case's grooves. It will auto-tap in aluminum.

#### 6.2.1 UNIVERSAL MOUNT

Phoxene can supply standard mount that provide six M5 threads and one standard 1/4" camera thread.



#### 6.2.2 2 AXES ORIENTABLE MOUNT

Phoxene can supply 2 axes orientable mounts that provide +/-22° horizontal and +/-45° vertical tilt adjustment.

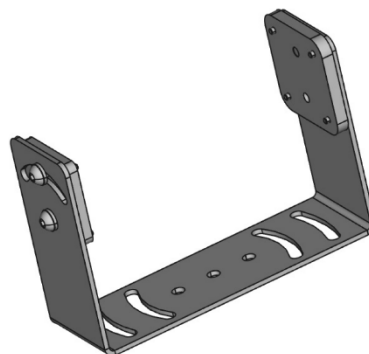

#### 6.2.3 CUSTOM MOUNTS

Phoxene can design, manufacture and assemble custom mounts to provide mounting points that fit your needs.

## 7 HARDWARE INTERFACE

### 7.1 BASIC CONNECTIONS

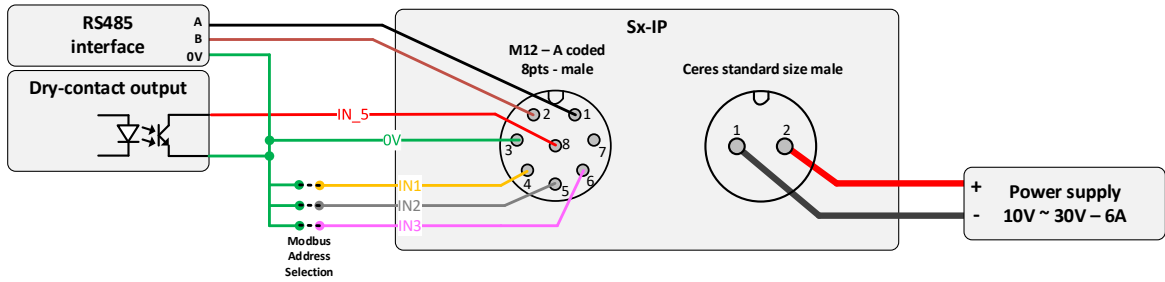

Figure 1 – Basic connections

### 7.2 POWER SUPPLY

Power supply input is through an **Amphenol Ceres** standard size 2pts male receptacle with male contacts.

Signal	Description	Wire color	Pinout
0V	Input supply return	Black	1
Vin	Input supply	Red	2

Table 1 – Ceres connector pinout

#### 7.2.1 MATTING CONNECTORS

Field installable Ceres connectors are available from PHOXENE.



#### 7.2.2 CABLES GAUGES AND LENGTH

Power supply cable shall be sized to handle the device maximum current with a limited voltage drop.

- **1mm<sup>2</sup>** wire gauge is acceptable for up to **6m**.
- **1.5mm<sup>2</sup>** wire gauge allows up to **10m**.

### 7.3 SIGNALS CONNECTOR

Signals are available through an M12 A code male/male connector. Three versions are available:

- **M12-8pts (standard).**
- M12-12pts that provide an additional 5V input and two isolated outputs (option).
- M12-5pts that reduce wiring cost and allows serial connection (option).

#### 7.3.1 M12 CONNECTORS PINOUT

M12 connectors pinout are as follows:

Signal	Description	M12-5pts	M12-8pts	M12-12pts	Dsub15 Dxx
RS485A	RS485 A	3	1	1	2
RS485B	RS485 B	1	2	2	1
0V	Reference	5	3	3	3
IO1	5V input / output	2	4	4	6
IN2	5V input	4	5	5	13
IN3	5V input		6	6	5
IN4	5V input			7	12
IO5	12V input / output	2	8	8	9
IN6	12V input	4	7	9	10
OUT7	Isolated output			10	4
OUT8	Isolated output			11	
COM	Isolated common			12	11

Table 2 – M12 connectors pinout and wire color

Design notes:

Outputs are not available on C04 revisions.

**Presented wires' colors are according to M12 usual conventions. Please note that M12 cables can comes with other color coding. Always refers to cable datasheet and respect to pinout.**

#### 7.3.2 MATTING CONNECTORS

Compatible field installable (screws) connectors from TE Connectivity:

- T4110001081-000 (Field installable M12-8pts female/female straight connector with PG7 gland)
- T4112012081-000 (Field installable M12-8pts female/female shielded right-angled connector with PG9 gland)

**Field installable M12 connectors are available from PHOXENE.**



#### 7.3.3 SHIELDING

M12 connector is shielded at SxIP side. Shielded M12 connector and cables are not mandatory but can be used to ensure good performances with high cable lengths or in harsh environment.

### 7.4 ADDRESS / LEVEL HARDWARE SELECTOR (OPTION)

Sx-IP devices can be fitted with a hardware selector accessible on the back panel.

Hardware selector allows easy and direct configuration of the Modbus device address or of the energy level.

Hardware selector is protected by a M16 IP67 plug.

### 7.5 USING M12-5PTS CONNECTORS FOR DAISY CHAINING SX-IP DEVICES

By using M12-5pts connectors and some standard M12 splitters, it is possible to daisy chain Sx-IP devices.

Using some splitters providing asymmetric routing (IN4 -> OUTA4 and IN2 -> OUTB4), it is possible to have separated hardware triggers on a single daisy chain.

Asymmetric splitter example:

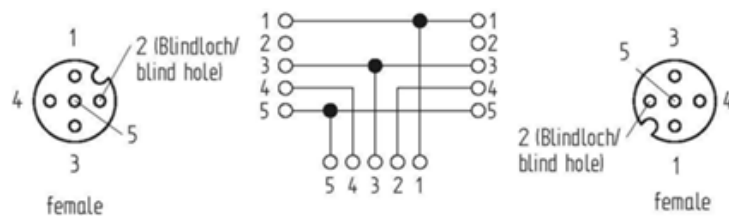

Figure 2 – M12 5pts splitter illustration

## 7.6 DSUB15 INTERFACE (OPTION)

As an option, Sx-IP is available with a single Female DA-15 (Dsub) interface.

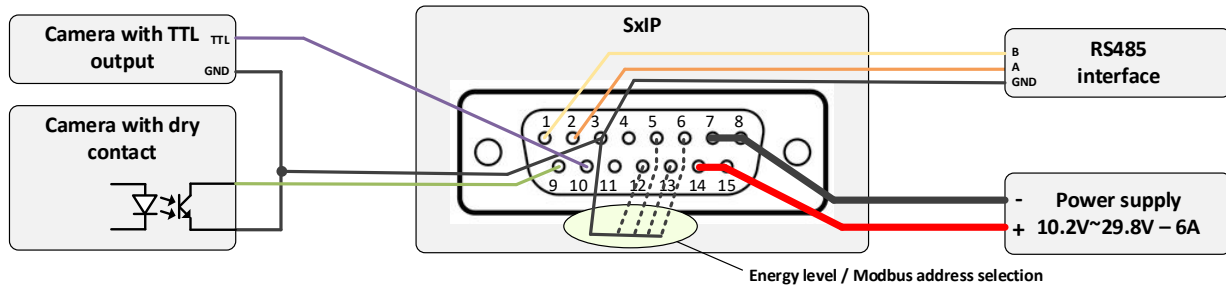

Figure 3 – Dsub15 version basic connections

### 7.6.1 DA-15 INTERFACE PINOUT

DA-15 connector pinout is as defined in Table 3.

Pin	Signal	Pin	Signal
1	RS485_B	9	IO5 (12V input or output)
2	RS485_A	10	IN6 (12V input)
3	0V	11	Isolated output reference (COM)
4	OUT7 (Isolated output)	12	IN4 (5V input)
5	IN3 (5V input)	13	IN2 (5V input)
6	IO1 (5V input or output)	14	Vin (dc supply input)
7	0V supply input	15	Vin (dc supply input)
8	0V supply input		

Table 3 – DA-15 connector pinout

### 7.6.2 MATCHING CONNECTOR

Matching connector could be any DA-15 male connector.

If a protection is required, we recommend to use following covers:

- Amphenol CONEC 165X14829XE
- NORCOMP 967-015-010R011 (7.62mm max cable diameter)

## 7.7 RS485 INTERFACE

RS485 interface is a 1/8 load standard RS485 interface. Up to 256 devices can be connected to a standard 32 unit load RS485 bus.

RS485 signals are referenced to 0V, supporting up to +12V/-7V common mode voltage.

#### Design notes:

For high bus lengths and/or high device count, please comply with RS485 state of the art design rules:

- Three wires bus (A, B and voltage reference (0V))
- Line bus topology with 1000m maximum length
- 120Ω termination resistors at both ends

## 7.8 DISCRETE IOS

Sx-LED provide up to eight discrete IOs:

I/O type	I/O name
5V input / output	IO1 <sup>(1)</sup>
5V inputs	IN2 <sup>(2)</sup> , IN3 <sup>(2)</sup> , IN4
12V input / output	IO5 <sup>(1)</sup>
12V input	IN6
Open drain isolated outputs (up to 24V)	OUT7 <sup>(1)</sup> and OUT8

*Design notes:*

*IN4, OUT7 and OUT8 are not available on the 8 points M12 interface but on 12points M12 12pts interface.*

*(1) OUT1, OUT 5 and OUT 8 are not available on COx hardware revision.*

*(2) Inputs 2 and 3 can be optionally wired as isolated inputs with custom pinout.*

### 7.8.1 SCHEMATIC DIAGRAMS OF INTERFACES

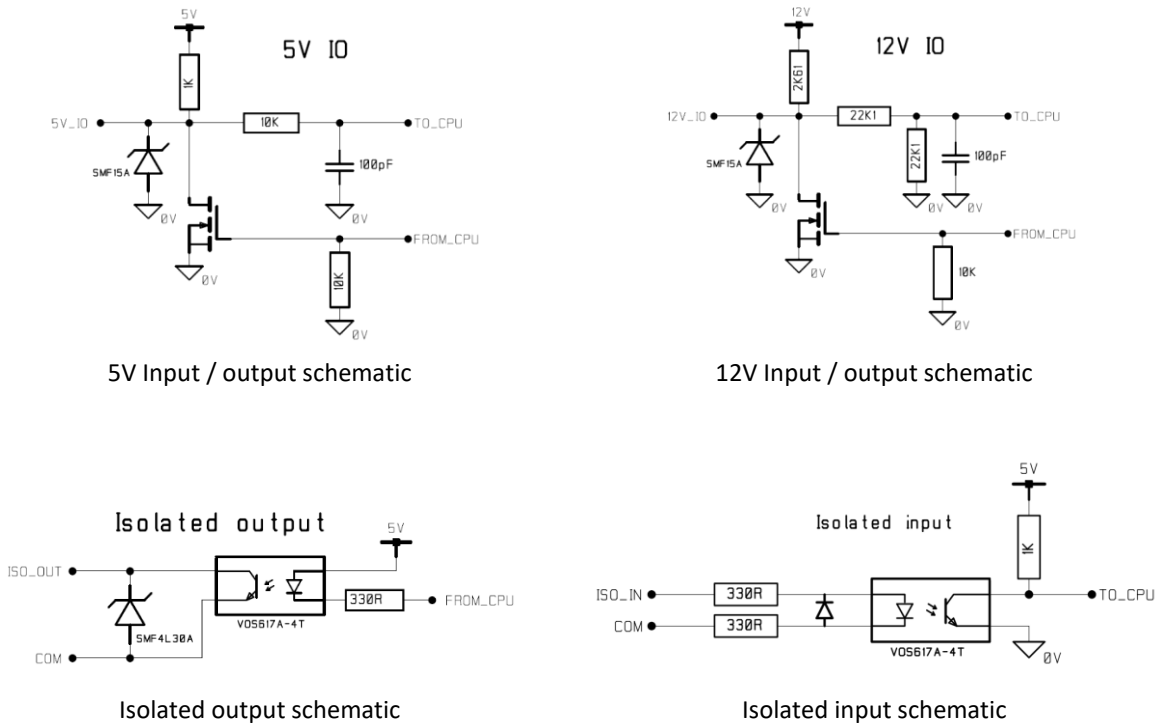

Figure 4 – Sx-LED Ios schematic diagram

### 7.8.2 5V INPUTS (IO1, IN2, IN3, IN4)

5V inputs are intended to be driven from a dry contact, open drain output or 5V push-pull outputs.

However, it is also possible to drive it from 3.3V push-pull outputs.

5V input are referenced to 0V.

5V input has internal 1kΩ pull-ups to the internal 5V rail.

5V inputs shall be pull to 0V with at least 5mA drive current.

Symbol	Characteristics	Value	Unit	Conditions
VIL <sub>max</sub>	Maximum input low voltage	1.0	V	Schmitt trigger buffer <sup>(1)</sup>
		0.8	V	TTL buffer <sup>(1)(2)</sup>
VIH <sub>min</sub>	Minimum input high voltage	4.0	V	Schmitt trigger buffer <sup>(1)</sup>
		2.0	V	TTL buffer <sup>(1)(2)</sup>
IL <sub>min</sub>	Minimum required drive current	5	mA	
TLH <sub>max</sub>	Maximum low to high transition delay	1	μs	
THL <sub>max</sub>	Maximum high to low transition delay	1	μs	

**Table 4 – 5V inputs electrical characteristics**

Design notes:

*When using mechanical switch, be careful with bounces that may cause multiple edges that may be interpreted as multiple flash request.*

*When using non-isolated open-drain input, be careful with common mode voltage.*

*When using phototransistors, make sure that it can sink 5mA in any case.*

<sup>(2)</sup> *Input buffer software selectable. TTL buffer can be selected to reduce the input voltage thresholds allowing compatibility with 3.3V outputs.*

<sup>(3)</sup> *TTL buffer is not windowed, it has lower immunity to perturbation than Schmitt trigger buffer.*

### 7.8.3 5V OUTPUT (IO1)

IO1 can be configured as a 5V output (open drain with 1kΩ to 5V internal rail).

Symbol	Characteristics	Value	Unit	Conditions
VOH <sub>min</sub>	Minimum output high voltage	4.0	V	1mA sourced from internal 5V
VOL <sub>max</sub>	Maximum output low voltage	0.4	V	50mA sink to 0V
VOL <sub>max</sub>	Maximum sink current	50	mA	
TLH <sub>max</sub>	Maximum low to high transition delay	1	μs	
THL <sub>max</sub>	Maximum high to low transition delay	1	μs	

**Table 5 – 5V output electrical characteristics**

Design notes:

*5V output is not protected from over-current. Care must be taken to limit the current flowing through it.*

#### 7.8.4 12V INPUTS (IO5 AND IN6)

12V inputs are intended to be driven from a dry contact, open drain output or 12V push-pull outputs.

However, it is also possible to drive it from 5V push-pull outputs.

12V input are referenced to 0V.

12V input has internal 2.61kΩ pull-ups to the internal 12V rail.

12V inputs shall be pull to 0V with at least 5mA drive current.

Symbol	Characteristics	Value	Unit	Conditions
VIL <sub>max</sub>	Maximum input low voltage	2.0	V	Schmitt trigger buffer <sup>(1)</sup>
		1.6	V	TTL buffer <sup>(1)(2)</sup>
VIH <sub>min</sub>	Minimum input high voltage	8.0	V	Schmitt trigger buffer <sup>(1)</sup>
		4.0	V	TTL buffer <sup>(1)(2)</sup>
IL <sub>min</sub>	Minimum required drive current	5	mA	
TLH <sub>max</sub>	Maximum low to high transition delay	2	μs	
THL <sub>max</sub>	Maximum high to low transition delay	2	μs	

**Table 6 – 12V inputs electrical characteristics**

Design notes:

*When using mechanical switch, be careful with bounces that may cause multiple edges that may be interpreted as multiple flash request.*

*When using non-isolated open-drain input, be careful with common mode voltage.*

*When using phototransistors, make sure that it can sink 5mA in any case.*

<sup>(1)</sup> *Input buffer software selectable. TTL buffer can be selected to reduce the input voltage thresholds allowing compatibility with 5V outputs.*

<sup>(2)</sup> *TTL buffer is not windowed, it has lower immunity to perturbations than Schmitt trigger buffer.*

#### 7.8.5 12V OUTPUT (IO5)

IO5 can be configured as a 12V output (open drain with 2.61kΩ to 12V internal rail).

Symbol	Characteristics	Value	Unit	Conditions
VOH <sub>min</sub>	Minimum output high voltage	9.0	V	1mA sourced from internal 5V
VOL <sub>max</sub>	Maximum output low voltage	0.4	V	50mA sink to 0V
VOL <sub>max</sub>	Maximum sink current	50	mA	
TLH <sub>max</sub>	Maximum low to high transition delay	1	μs	
THL <sub>max</sub>	Maximum high to low transition delay	1	μs	

**Table 7 – 12V output electrical characteristics**

Design notes:

*12V output is not protected from over-current. Care must be taken to limit the current flowing through it.*

### 7.8.6 ISOLATED OUTPUTS (OUT7 AND OUT8)

OUT7 and OUT8 are isolated open drain outputs. They support up to 28V and can drive up to 10mA.

Reverse voltages are short-circuited by a diode.

Symbol	Characteristics	Value	Unit	Conditions
$V_{O_{max}}$	Maximum bias voltage	28	V	
$V_{OL_{max}}$	Maximum output low voltage	0.4	V	10mA sink to 0V
$I_{OL_{max}}$	Maximum sink current	10	mA	
$TLH_{max}$	Maximum low to high transition delay	20	$\mu$ s	
$THL_{max}$	Maximum high to low transition delay	4	$\mu$ s	

**Table 8 – Isolated outputs electrical characteristics**

Design notes:

*Isolated outputs are not protected from over-current. Care must be taken to limit the current flowing through them.*

### 7.8.7 ISOLATED INPUT (IN2 AND IN3) AS AN OPTION

IN2 and IN3 can be optionally wired as isolated inputs. They support 5V and 12V drive.

Reverse voltages are short-circuited by a diode.

Symbol	Characteristics	Value	Unit	Conditions
$V_{IL_{max}}$	Maximum input low voltage	0.8	V	
$V_{IH_{min}}$	Minimum input high voltage	4.8	V	
$I_{L_{min}}$	Minimum required drive current	5	mA	@5V
		16	mA	@12V
$TLH_{max}$	Maximum low to high transition delay	20	$\mu$ s	
$THL_{max}$	Maximum high to low transition delay	4	$\mu$ s	

**Table 9 – Isolated inputs electrical characteristics**

## 8 CONFIGURATION

Sx-IP is a very versatile device; many parameters can be adjusted using the Modbus communication link.

For information about how to configure the device through using the RS485 Modbus link, refers to the Sx-IP Modbus Manual.

Some settings (Modbus or energy level) can be done through hardware selection using some available inputs and or the optional selector.

Design notes:

*Sx-IP devices are factory configured with the parameters you requested or with those we believe to be most appropriate for your application.*

### 8.1 HARDWARE SETTINGS

#### 8.1.1 HARDWARE SELECTION OF AN ENERGY LEVEL

One of the eight pre-programmed energy levels can be set accordingly to a combination of software values and discrete inputs.

A basic usage is to set the energy levels (1 to 16) by hardware configuration (some of the discrete inputs shorted to 0V). An optional back-side selector can also be used to configure the energy level.

#### 8.1.2 HARDWARE MODBUS ADDRESS SELECTION

The Modbus address of the device can be set accordingly to a combination of software values and discrete inputs.

A basic usage is to set part or all of the Modbus address (1 to 247) by hardware configuration (some of the discrete inputs shorted to 0V). An optional back-side selector can also be used to set the Modbus address.

#### 8.1.3 ALTERNATE ENERGY LEVEL SELECTION (DAY / NIGHT)

One of the inputs can be configured for alternate energy selection. It allows to switch between two pre-configured energy levels using a discrete input (without use of Modbus communication). It is mainly used to adapt the flash energy to lighting conditions (day/night, sunny/cloudy...)

Design notes:

*The input selected for alternate energy selection is polled every 1ms.*

## 9 MAINTENANCE INSTRUCTIONS



All following instructions must be carried out by High Voltage qualified and trained staff only

### 9.1 FLASH TUBE REPLACEMENT



**Before opening the housing, disconnect the Sx-IP then wait at least 30minutes.**

**Always wear qualified for protection glasses.**

**Until that capacitors' voltages have been verified to be lower than 12V, use 1000V rated Personal Protective Equipment**

**When the 30 minutes are elapsed:**

- Remove the 4 screws on the front side of the product (flash tube side).
- Remove the front panel



**Using a VAT, check that there is not voltage (less than 12V) between the following points:**

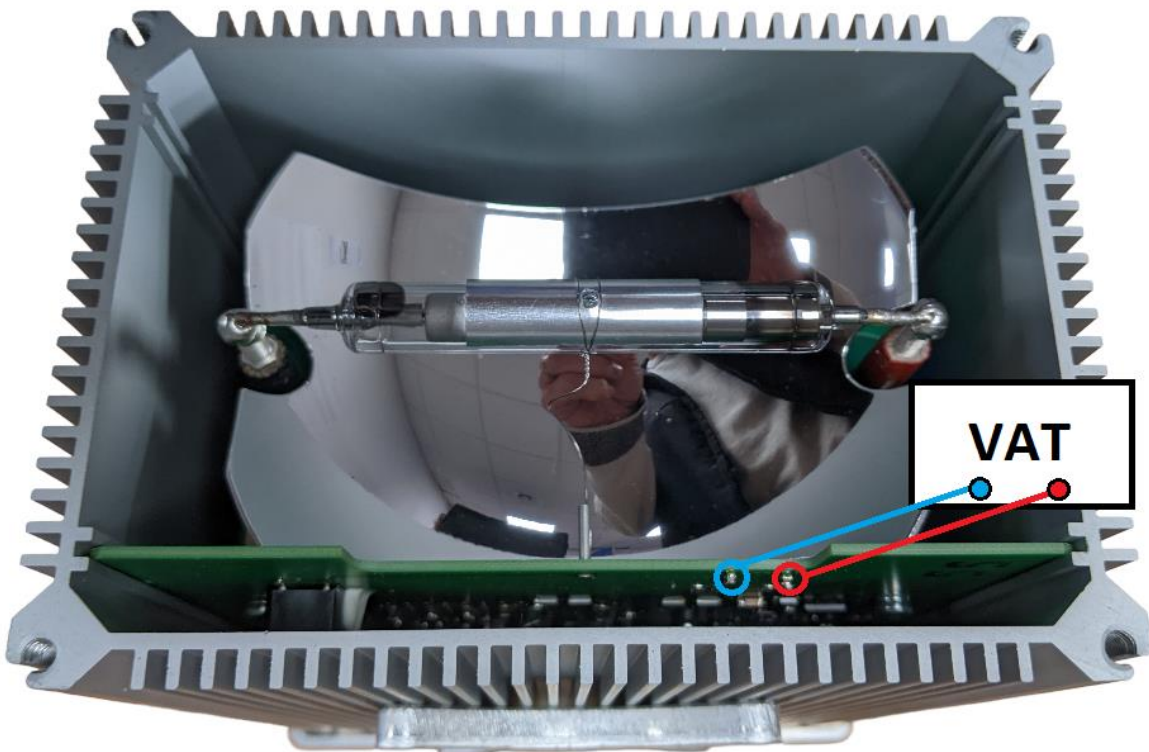

Figure 5 – VAT on a Sx-IP with D0x hardware revision

**When all the safety measures are met:**

- Remove the old flash tube by pulling it by both ends.
- Insert the new flash tube, then insert the trigger wire in the dedicated receptacle.
- The trigger wire is just placed in the cylindrical receptacle. It is intended to transmit the high voltage trigger impulse (10 kV) that doesn't require a full electrical contact.

**When the new flash tube is in place:**

- Check that glass is in good condition
- Check that the seal is in good condition and position
- Put back the front panel
- Tighten the four screws (1.5N.m)

**9.2 FUSES REPLACEMENT:**

This product is equipped with several fuses; **their replacement must be done by Phoxene at warehouse.**